



**STRONG PARTNERS.
TOUGH TRUCKS.™**



H30-40FT SERIES TECHNICAL GUIDE

WWW.HYSTER.COM

> H30-40FT DIMENSIONS

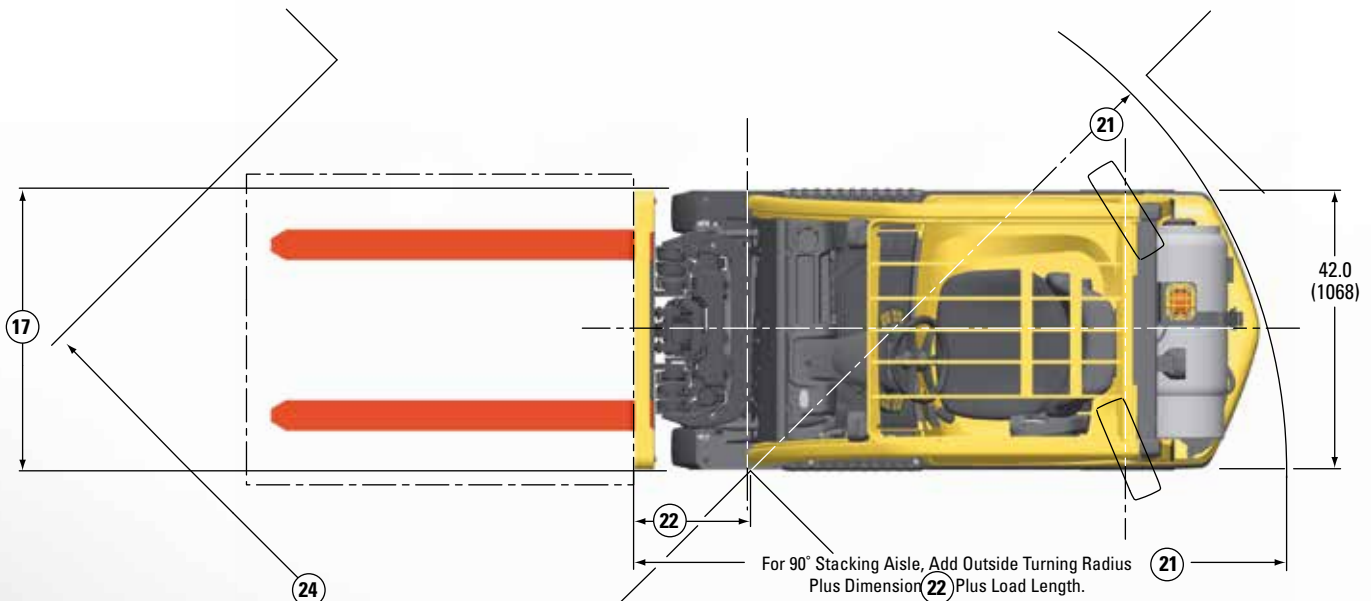

MODEL	LIFT CAPACITY	LOAD CENTER	F	G	J	L
	lb (kg)	in (mm)	percent	percent	in (mm)	in (mm)
H30FT	3000 (1360)	24 (610)	42%	47.0%	27.2 (691)	14.6 (371)
H35FT	3500 (1587)	24 (610)	42%	47.0%	27.2 (691)	14.6 (371)
H40FTS	4000 (1814)	24 (610)	39%	47.0%	27.2 (691)	14.6 (371)

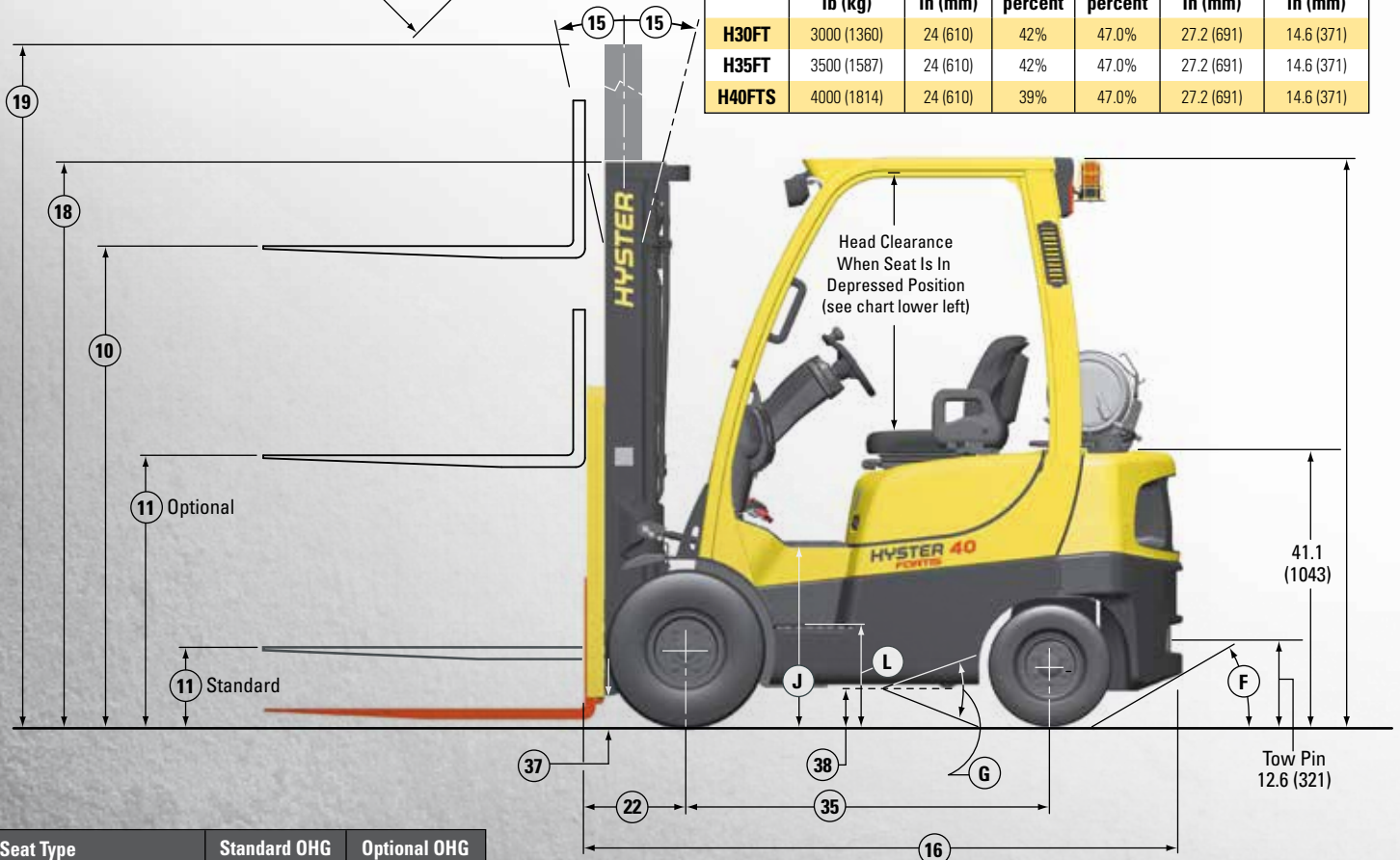

Seat Type	Standard OHG	Optional OHG
	in (mm)	in (mm)
Non-Suspension	42.0 (1067)	39.4 (1001)
Semi-Suspension	42.5 (1079)	39.9 (1013)
Full-Suspension	42.0 (1067)	N/A
Swivel Full-Suspension	42.0 (1067)	N/A

> H30-40FT SPECIFICATIONS

		Hyster Company				
		H30FT	H35FT	H40FTS		
GENERAL	1	Manufacturer Name	Hyster Company			
	2	Model	H30FT	H35FT	H40FTS	
		Engine	PSI 2.0L			
	3	Rated Capacity	lb (kg)	3000 (1360)	3500 (1587)	4000 (1814)
	4	Load Center, Distance	in (mm)	24.0 (610)		
	5	Power Type	LPG			
	6	Operator Type	Sit-Down Rider			
	7	Step Height	in (mm)	14.6 (371)		
	8	Tire Type - Cushion, Solid, Pneumatic	Pneumatic			
DIMENSIONS	9	Wheels, Number - Front/ Rear	2x/2			
	10	Lift Height, Top of Fork (TOF)	in (mm)	127 (3232)		
	11	Lift Heights, Standard Limited Free Lift (LFL) w/o LBR (TOF)	in (mm)	5 (140)		
		Lift Heights, Optional Full Free Lift (FFL) w/o LBR (TOF)	in (mm)	35 (902)		
	12	Standard Carriage Width	in (mm)	38.5 (978)		
	13	Forks, Thickness x Width x Length	in	1.6 X 3.9 X 42.0		
		Forks, Thickness x Width x Length	(mm)	(40 X 100 X 1067)		
	14	Fork Spread, Outside Dimensions	in (mm)	37.5 (955)		
	15	Mast Tilt Angles, Forward/Backward	degrees	6F/6B		
	16	Length To Face of Forks	in (mm)	88.1 (2239)	89.4 (2271)	
	17	Overall Width, Standard Tread	in (mm)	42.0 (1068)		
		Overall Width, Wide Tread	in (mm)	48.7 (1238)		
	18	Height, Standard Mast - Lowered	in (mm)	84 (2125)		
	19	Height, Standard Mast - Extended with LBR	in (mm)	176 (4455)		
		Height, Standard Mast - Extended without LBR	in (mm)	150 (3806)		
	20	Height, Standard Overhead Guard	in (mm)	84.6 (2149)		
		Height, Optional Overhead Guard	in (mm)	81.9 (2081)		
	21	Turning Radius, Minimum Outside (OTR)	in (mm)	77.0 (1955)	78.1 (1985)	
	22	Length, Center of Wheel to Face of Forks	in (mm)	15.1 (384)		
	23	Aisle Width, Right Angle Stack (Add Length of Load)	in (mm)	92.1 (2339)	93.3 (2369)	
	24	Equal Aisle, 90-Degree Intersecting Aisle	in (mm)	73.9 (1830)	74.4 (1855)	
	PERFORMANCE	25	Travel Speed RL/NL	mph (km/h)	13.1/13.4 (21.1/21.5)	
		26	Lift Speed, Standard 2-Stage LFL RL/NL	ft/min (m/s)	114/118 (.58/.60)	
			Lift Speed, Optional 2-Stage FFL RL/NL	ft/min (m/s)	102/106 (.52/.54)	
		Lift Speed, Optional 3-Stage FFL RL/NL	ft/min (m/s)	106/110 (.54/.56)		
27		Lowering Speed, Standard 2-Stage LFL RL/NL	ft/min (m/s)	100/92 (.51/.47)		
		Lowering Speed, Optional 2-Stage FFL RL/NL	ft/min (m/s)	91/73 (.46/.37)		
		Lowering Speed, Optional 3-Stage FFL RL/NL	ft/min (m/s)	94/81 (.48/.41)		
28		Drawbar Pull @ 1 mph RL/NL	lb (kg)	2568/1933 (1165/877)	2560/1918 (1161/870)	2546/1870 (1155/848)
29		Gradeability @ 1 mph RL/NL ††	%	28/30	26/29	24/27
WT.		30	Weight, Standard Truck (2-Stg. LFL) NL	lb (kg)	6367 (2888)	6533 (2963)
		Weight, Standard Truck (2-Stg. LFL) RL	lb (kg)	9367 (4249)	10033 (4551)	10883 (4937)
	32	Axle Loading, Static Front/Rear NL	lb (kg)	2876/3492 (1305/1584)	2842/3691 (1289/1674)	2750/4134 (1247/1875)
		Axle Loading, Static Front/Rear RL	lb (kg)	8021/1346 (3638/611)	8846/1187 (4013/538)	9611/1272 (4360/577)
TIRES & WHEELS	33	Tire Size, Front	6.50 x 10 - 10			
	34	Tire Size, Rear	5.00 x 8.00			
	35	Wheelbase	in (mm)	54.5 (1385)		
	37	Ground Clearance, Lowest Point NL (with RL subtract 6mm)	in (mm)	5.3 (135)		
	38	Ground Clearance, Center of Wheelbase NL	in (mm)	5.7 (146)		
	39	Service Brake - Method of Control/Operation	Foot/Hydraulic			
	40	Parking Brake - Method of Control/Operation	Hand/Mechanical			
POWERTRAIN	41	Battery Type	Maintenance Free			
	42	Volts/Cold Cranking Amps	v/cca	12/475		
	43	Engine, Manufacturer/Model	PSI 2.0L			
	44	Permanent Output	hp (Kw)	44 (33)		
	45	Torque @ Rated RPM	ft Lbs (kg/m)	100 (13.9) @ 1300 RPM		
	46	Number of Cylinders/Displacement	No/cc (ci)	4/1997 (122)		
		Standard Speeds, Forward - Reverse	1-1			
	51	Auxiliary Hydraulic Pressure Relief for Attachments	PSI (Mpa)	2300 (15.9)		

NOTE: Above specifications, unless otherwise listed, are for a standard truck without optional equipment. Right Angle Stack and Equal Intersecting Aisle are calculated using a 40" wide pallet.

CERTIFICATION: Hyster lift trucks meet the design and construction requirements of B56.1-1969, per OSHA Section 1910.178(a)(2), and also comply with the B56.1 revision in effect at time of manufacture. Certification of compliance with the applicable ANSI standards appears on the lift truck. Performance specifications are for a truck equipped as described under Standard Equipment on this Technical Guide. Performance specifications are affected by the condition of the vehicle and how it is equipped, as well as by the nature, condition of the operating area, proper service and maintenance of the vehicle. If these specifications are critical, the proposed application should be discussed with your dealer.

H30-40FT SPECIFICATIONS



H30-35FT, H40FTS MAST DIMENSIONS								
Maximum Fork Height (TOF) †	Overall Lowered Height	Overall Extended Height		Free lift (TOF)		Approx. Total Weight of Standard Equipped Truck w/o Load		
		with LBR	w/o LBR	with LBR	w/o LBR	H30FT	H35FT	H40FTS
in (mm)	in (mm)	in (mm)	in (mm)	in (mm)	in (mm)	lbs (kg)	lbs (kg)	lbs (kg)
2-STAGE LIMITED FREE LIFT (LFL) VISTA™ MAST								
83 (2132)	62 (1575)	133 (3355)	107 (2706)	5 (140)	5 (140)	6170 (2799)	6335 (2873)	6686 (3033)
123 (3132)	82 (2075)	172 (4355)	146 (3706)	5 (140)	5 (140)	6350 (2880)	6515 (2955)	6866 (3114)
127 (3232)	84 (2125)	176 (4455)	150 (3806)	5 (140)	5 (140)	6367 (2888)	6532 (2963)	6868 (3122)
2-STAGE FULL FREE LIFT (FFL) VISTA™ MAST								
114 (2918)	78 (1975)	164 (4141)	138 (3492)	29 (752)	52 (1346)	6391 (2899)	6556 (2974)	6907 (3133)
126 (3218)	84 (2125)	176 (4461)	150 (3792)	35 (902)	57 (1456)	6449 (2925)	6614 (3000)	6965 (3159)
3-STAGE FULL FREE LIFT (FFL) VISTA™ MAST								
175 (4450)	80 (2025)	224 (5673)	198 (5019)	31 (802)	53 (1356)	6649 (3016)	6814 (3091)	7165 (3250)
187 (4750)	84 (2125)	236 (5973)	210 (5319)	35 (902)	57 (1456)	6694 (3036)	6859 (3111)	7210 (3270)
198 (5050)	90 (2275)	247 (6273)	222 (5619)	41 (1052)	63 (1606)	6757 (3065)	6922 (3140)	7273 (3299)
216 (5510)	96 (2425)	265 (6723)	239 (6069)	47 (1202)	69 (1756)	6874 (3118)	7039 (3193)	7390 (3352)

TRUCK CONFIGURATION:

- 3-stage FFL mast (169.2 in MFH for H30FT, 163.4 in MFH for H35FT & 151.6 in MFH for H40FTS)
- 38.5" (978 mm) standard carriage with load backrest (LBR).
- Basic truck equipped with the PSI 2.0L LPG engine with single-speed electronic powershift transmission.
- Standard tires and tread.

RATED LOAD vs. LOAD CENTER
STANDARD CARRIAGE
U. S. CUSTOMARY

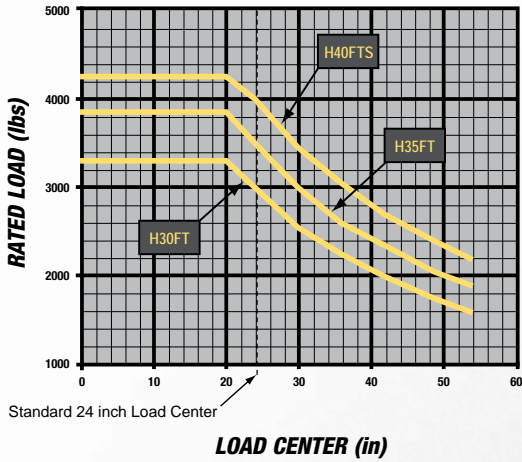

RATED LOAD vs. LOAD CENTER
INTEGRAL CARRIAGE
U. S. CUSTOMARY

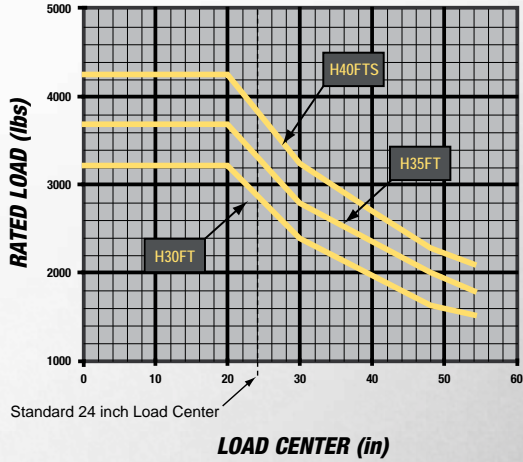

RATED LOAD vs. LOAD CENTER
STANDARD CARRIAGE
METRIC

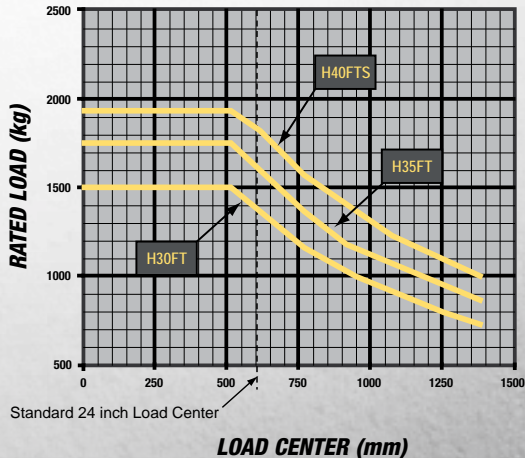

RATED LOAD vs. LOAD CENTER
INTEGRAL CARRIAGE
METRIC

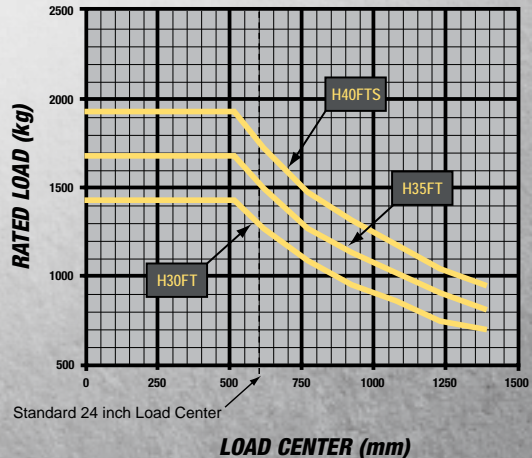

➤ STANDARD FEATURES AND OPTIONS

STANDARD EQUIPMENT

Complete truck equipped with:

- PSI 2.0L LPG
- Electronic powershift transmission
 - Electronic inching
 - Electronic shift control
 - Neutral start switch
- Anti-restart protection
- MONOTROL® pedal
- 2-stage limited free lift (LFL) VISTATM mast with maximum fork height of 127" (3232 mm)
- 38.6" (978 mm) wide hook-type carriage with 48" (1219 mm) tall load backrest
- 42" (1067 mm) long forks
- 6 degrees forward and 6 degrees backward mast tilt
- 3-function valve and hose group
- Integrated dashboard display includes:
 - LCD Display:
 - Hour meter
 - Coolant temp
 - Clock
 - Messages
 - Service/Operational Indicator Lights:
 - Alternator
 - Transmission oil temperature
 - Engine oil pressure
 - Brake fluid level
 - Fasten seat belt
 - Low LP fuel level
 - Engine malfunction
 - System malfunction
 - Park brake
 - Water temp
 - Forward, reverse and neutral direction indicators
- Hydrostatic power steering
- Non-suspension vinyl seat
- Electronic horn
- Adjustable steer column
- Rubber floor mat
- High air intake
- Integral tie downs
- Operator restraint system
- Square-wave anti-clog radiator
- Single pedal inch brake
- Hyster Stability System (HSS®)
- Cowl-mounted hydraulic control levers
- Swing-out LPG tank bracket
- 85" (2149 mm) overhead guard
- 12 months / 2,000 hours manufacturer's warranty
- 12 months / 4,000 hours manufacturer's powertrain warranty
- Operator's manual
- UL Classification LP

OPTIONAL EQUIPMENT

- DuraMatch™ transmission
 - Auto deceleration system
 - Controlled power reversal feature
 - Controlled rollback on ramps
- Powertrain protection system
- Premium electronic monitoring
- High air intake with precleaner
- 2-stage LFL 83" (2132 mm) trucker's style mast
- Keyless start (with auxiliary key switch)
- TouchPoint electro-hydraulic controls
- Rear drive handle with horn button
- 82" (2082 mm) short overhead guard
- Polycarbonate overhead guard rain top
- Full-suspension seat – vinyl or cloth
- Semi-suspension seat - vinyl or cloth
- High-visibility non-cinch seat belt with or without interlock
- Dual inch brake pedals
- EZXchange LPG tank bracket
- Password protection
- Dual side view mirrors
- Audible alarm - reverse activated 82-102 dB(A) self-adjusting
- Visible alarm amber strobe light - continuous activated, overhead guard mounted
- Various light packages
 - Two brake/back-up high intensity LED lights
 - Two front and one rear halogen or LED work lights
 - Two front, one rear halogen or LED work light and two brake/tail/back-up high intensity LED lights
- Parts publications - printed or CD, serial number specific
- UL Classification LPS
- Pneumatic shaped solid tires
- Various tread widths available
- Operator pre-shift checklist
- Load weight display
- Impact monitor
- Integral sideshifter with or without fork positioner



Hyster Company
P.O. Box 7006
Greenville, North Carolina
27835-7006
Part No. H30-40FTS/TG
12/2017 Litho in U.S.A.

Visit us online at www.hyster.com or call us at **1-800-HYSTER-1**.

Hyster, , and STRONG PARTNERS. TOUGH TRUCKS. and MONOTROL are registered trademarks in the United States and certain other jurisdictions. Hyster products are subject to change without notice.

Trucks may be shown with optional equipment. © 2017 Hyster Company. All rights reserved.